

NO	QTY	PART NO	DESCRIPTION	STD SEAL KIT	LIGHT SPRING KIT	HEAVY SPRING KIT
1	1	23350089	SPRING, COMPRESSION		X	X
2	1	23350091	SPRING, COMPRESSION			X
3	1	39000035	O-RING, (-015)	X	X	X
4	1	39051090	O-RING, (6.7mm x 1.8)	X	X	X
5	1	39051091	O-RING, (7.5mm x 1.5)	X	X	X
6	1	39051099	O-RING, (-030)	X	X	X
7	1	39053048	WIPER, PRESS-IN, 16mm	X		
8	1	81000000	CONTACT BOLT, WS, 7MPa, 5.5 & 10kN			
9	1	23350090	SPRING, COMPRESSION		X	
N/A	N/A	L6010001	KIT, SEAL, WS, 7MPa, CM/BM, 10kN	NOTED	N/A	N/A
N/A	N/A	L6110010	KIT, SPRING, WS, 7MPa, CM/BM, FA, 10kN	N/A	NOTED	N/A
N/A	N/A	L6110011	KIT, SPRING, WS, 7MPa, CM/BM, FA, 10kN	N/A	N/A	NOTED
N/A	N/A	ISL1007	INSTRUCTION SHEET, WS, 7MPa, CM/BM, FA, 10kN	N/A	N/A	N/A

See Instruction Sheet ISL1007 For Service Instructions.  
 Lubricate All Seals With Clean Hydraulic Oil Prior To Assembly.  
 Do Not Use Silicone Base Lubricants.



<b>PARTS LIST</b>	 VEKTEK, INC. 1334 E. SIXTH AVE. P.O. BOX 625 EMPORIA, KS. 66801 U.S.A.
	<b>PARTS LIST, ASSY, WS, 7MPa, CM, FA, 10kN</b>
ASSEMBLIES AFFECTED L1-0416-00H L1-0416-00L	SIZE A <b>LPL1007</b>
FORM FEG035_PL_ASIZE, REV. B	

C	2846	RELEASE	Two	05/01/15
REV	IN ACCORDANCE WITH ECN	EFFECTIVE DATE	REVISED BY	DATE
DRW BY:	N.KARRAS	<b>DRAWING STATUS: Released</b>		
DATE:	03/21/14	PRODUCTION APPROVED FOR RELEASED STATUS ONLY		

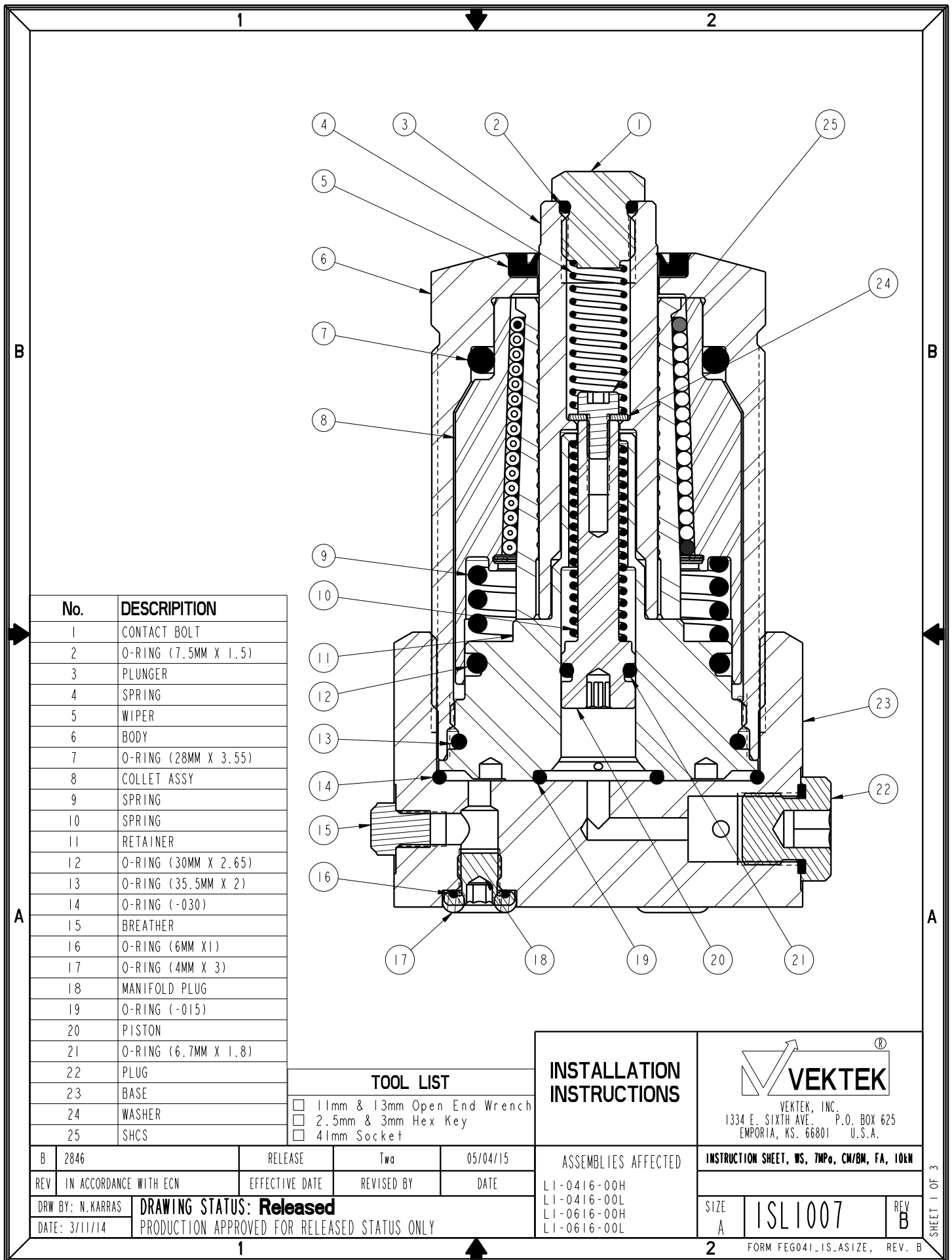

No.	DESCRIPTION
1	CONTACT BOLT
2	O-RING (7.5MM X 1.5)
3	PLUNGER
4	SPRING
5	WIPER
6	BODY
7	O-RING (28MM X 3.55)
8	COLLET ASSY
9	SPRING
10	SPRING
11	RETAINER
12	O-RING (30MM X 2.65)
13	O-RING (35.5MM X 2)
14	O-RING (-030)
15	BREATHER
16	O-RING (6MM X1)
17	O-RING (4MM X 3)
18	MANIFOLD PLUG
19	O-RING (-015)
20	PISTON
21	O-RING (6.7MM X 1.8)
22	PLUG
23	BASE
24	WASHER
25	SHCS

TOOL LIST	
<input type="checkbox"/>	11mm & 13mm Open End Wrench
<input type="checkbox"/>	2.5mm & 3mm Hex Key
<input type="checkbox"/>	41mm Socket

**INSTALLATION INSTRUCTIONS**

VEKTEK, INC.  
1334 E. SIXTH AVE. P.O. BOX 625  
EMPORIA, KS. 66801 U.S.A.

B	2846	RELEASE	Two	05/04/15
REV	IN ACCORDANCE WITH ECN	EFFECTIVE DATE	REVISED BY	DATE
DRW BY:	N. KARRAS	<b>DRAWING STATUS: Released</b>		
DATE:	3/11/14	PRODUCTION APPROVED FOR RELEASED STATUS ONLY		

ASSEMBLIES AFFECTED  
 LI-0416-00H  
 LI-0416-00L  
 LI-0616-00H  
 LI-0616-00L

INSTRUCTION SHEET, WS, 7MP, CM/BM, FA, 10LN	
SIZE A	ISL1007
REV B	

SHEET 1 OF 3

**Read all instructions before disassembly**  
**Refer to the illustration on page 1 for component part numbers and tool list**  
**Disassembly**  
**Model Number L1-0416-00H & L1-0416-00L**

1. Using a 41mm socket, unscrew work support from fixture or base. Wipe clean to remove external contaminants.
2. Remove O-ring (19) from retainer (11) s'face or cavity. Be careful not to damage retainer (11) face.
3. Remove O-ring (14) from fixture or base (23) cavity.
4. With 13mm wrench at plunger (3) and 11mm wrench at contact bolt (1), unscrew contact bolt (1) from plunger (3). Remove O-ring (2) from contact bolt (1).
5. Remove contact spring (4) from inside plunger (3).
6. Insert 3mm hex key into piston (20) from bottom of work support to prevent turning. Insert 2.5mm hex key into cap screw (25) inside plunger (3) and unscrew cap screw (25). Remove cap screw (25) and washer (24) from inside plunger (3). NOTE: PISTON (20) IS LOOSE AND NO LONGER FASTENED TO THE ASSEMBLY
7. Remove piston (20) and return spring (10) from inside retainer (11). Remove O-ring (21) from piston (20). CAUTION: RETURN SPRING (10) AND CONTACT SPRING (4) ARE NOT INTERCHANGEABLE, NOTE LOCATION AND KEEP SEPARATE FOR REASSEMBLY.
8. Gently slide plunger (3) out from top of work support.
9. Remove wiper (5) from top of body (6). Be careful not to damage wiper bore or bore below wiper (5). To assist holding body (6) during wiper (5) removal, body (6) may be threaded into base (23) or fixture, be careful not to damage the body (6) or retainer (11) face
10. Thoroughly clean contact bolt (1), contact spring (4), plunger (3), cap screw (25), washer (24), piston (20), return spring (10) and set aside to dry.
11. Wipe clean retainer (11) face located on bottom of work support. Wipe clean wiper bore located in body at top of work support.
12. Wipe clean work support cavity in fixture.

**Model Number L1-0616-00H & L1-0616-00L**

13. Remove work support base (23) from fixture and complete disassembly steps 1-11.
14. If work support hydraulics or vent is manifold fed from fixture, remove O-ring (17) from manifold s'face on base mounting face (2 places).
15. If work support hydraulics or vent is not manifold fed, insert 3mm hex key into plug (18) located at base mounting face and unscrew plug (2 places). Remove O-ring (16) from plug.
16. Thoroughly clean base (23), plugs (18) and set aside to dry.

**Caution: Do not expose work support clamping mechanism (8) located above retainer (11) to any type of cleaning solutions. Removal of retainer (11) or clamping mechanism (8) terminates product warranty.**

		
VEKTEK, INC. 1334 E. SIXTH AVE. P.O. BOX 625 EMPORIA, KS. 66801 U.S.A.		
INSTRUCTION SHEET, WS, 7MPo, CW/BM, FA, 10LN		
SIZE A	ISL1007	REV B
FORM FEG041-1S-ASIZE, REV. B		

## Assembly

### Model Number L1-0416-00H & L1-0416-00L

1. Lubricate new O-rings (2),(14),(19),(21) and outside diameter of new wiper (5) with clean hydraulic oil (Vekttek 65-0010-01 or equivalent). Also, apply light film of hydraulic oil to outside surface of plunger (3)
2. Press wiper (5) into top of body (6) taking extra care to install squarely without excess force. CAUTION: IMPROPER INSTALLATION COULD DAMAGE WIPER (5) CAUSING EXCESS WIPER DRAG.
3. Gently install plunger (3) into work support through wiper (5) taking care not to damage wiper (5). Plunger (3) should move freely without binding. Lightly push plunger (3) downward until bottoms.
4. Install O-ring (21) onto piston (20).
5. Slide return spring (10) onto piston (20) and insert piston (20) and return spring (10) into retainer (11) bore. Insert 3mm hex key into piston (20) and push inward to compress return spring (10). While holding piston (20) and return spring (10) in compressed position place washer (24) onto cap screw (25) and drop thread side down into hole through top of plunger (3). Insert 2.5mm hex key into cap screw (25) and torque to 2.5 N-m (20 in-lb). CAUTION: CONTACT SPRING (4) AND RETURN SPRING (10) ARE NOT INTERCHANGEABLE.
6. Insert contact spring (4) into hole through top of plunger (3). Contact spring (4) will pilot onto cap screw (25).
7. Install O-ring (2) onto contact bolt (1).
8. Screw contact bolt (1) into top of plunger (3). With 13mm wrench at plunger (3) and 11mm wrench at contact bolt (1) torque to 9 N-m (80 in-lb).
9. Install O-ring (19) into retainer (11) s`face.
10. Install O-ring (14) into bottom of fixture cavity.
11. Using 41mm socket, screw work support into fixture cavity. Torque to 55 N-m (40 ft-lb).

### Model Number L1-0616-00H & L1-0616-00L

12. Complete assembly steps 1-9.
13. Install O-ring (14) into bottom of base (23) cavity.
14. Using 41mm socket, screw work support into base (23) cavity. Torque to 55 N-m (30 ft-lb).
15. If work support hydraulics or vent is manifold fed from fixture, install new O-ring (17) into manifold s`face on base (23) mounting face (2 places).
16. If work support hydraulics or vent is not manifold fed, install O-ring (16) onto plug (18), insert 3mm hex key into plug (18) and torque to 3 N-m (25 in-lb) (2 places).

		
<small>VEKTEK, INC. 1334 E. SIXTH AVE. P.O. BOX 625 EMPORIA, KS. 66801 U.S.A.</small>		
<b>INSTRUCTION SHEET, WS, 7MPo, CW/BM, FA, 10&amp;N</b>		
SIZE A	<b>ISL1007</b>	REV B
<small>FORM FEG041-1S-ASIZE, REV. B</small>		